

File Systems

Main Points

- File layout
- Directory layout

File System Design Constraints

- For small files:
 - Small blocks for storage efficiency
 - Files used together should be stored together
- For large files:
 - Contiguous allocation for sequential access
 - Efficient lookup for random access
- May not know at file creation
 - Whether file will become small or large

File System Design

- Data structures
 - Directories: file name -> file metadata
 - Store directories as files
 - File metadata: how to find file data blocks
 - Free map: list of free disk blocks
- How do we organize these data structures?
 - Device has non-uniform performance

Design Challenges

- Index structure
 - How do we locate the blocks of a file?
- Index granularity
 - What block size do we use?
- Free space
 - How do we find unused blocks on disk?
- Locality
 - How do we preserve spatial locality?
- Reliability
 - What if machine crashes in middle of a file system op?

File System Design Options

	FAT	FFS	NTFS
Index structure	Linked list	Tree (fixed, assym)	Tree (dynamic)
granularity	block	block	extent
free space allocation	FAT array	Bitmap (fixed location)	Bitmap (file)
Locality	defragmentation	Block groups + reserve space	Extents Best fit defrag

Named Data in a File System

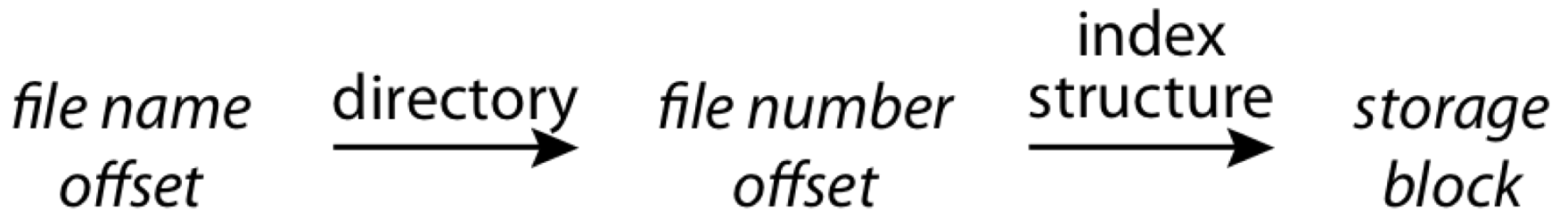

Microsoft File Allocation Table (FAT)

- Linked list index structure
 - Simple, easy to implement
 - Still widely used (e.g., thumb drives)
- File table:
 - Linear map of all blocks on disk
 - Each file a linked list of blocks

FAT

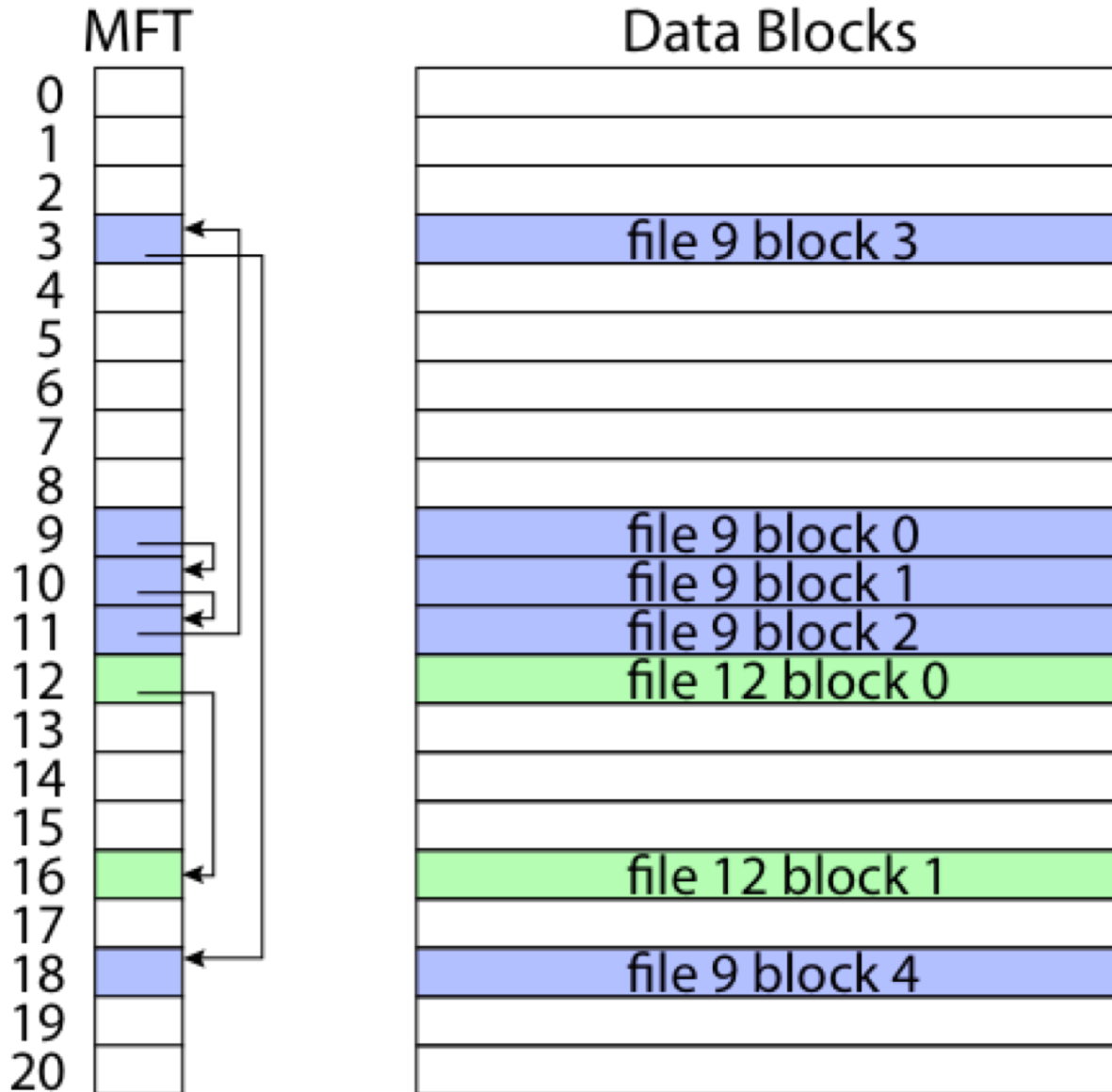

FAT

- Pros:
 - Easy to find free block
 - Easy to append to a file
 - Easy to delete a file
- Cons:
 - Small file access is slow
 - Random access is very slow
 - Fragmentation
 - File blocks for a given file may be scattered
 - Files in the same directory may be scattered
 - Problem becomes worse as disk is used

Berkeley UNIX FFS (Fast File System)

- inode table
 - (very roughly) Analogous to FAT table
- inode
 - Metadata
 - File owner, access permissions, access times, ...
 - Set of 12 data pointers
 - With 4KB blocks => max size of 48KB files

FFS inode

- Metadata
 - File owner, access permissions, access times, ...
- Set of 12 data pointers
 - With 4KB blocks => max size of 48KB files
- Indirect block pointer
 - pointer to disk block of data pointers
- Indirect block: 1K data blocks => 4MB (+48KB)

FFS inode

- Metadata
 - File owner, access permissions, access times, ...
- Set of 12 data pointers
 - With 4KB blocks => max size of 48KB
- Indirect block pointer
 - pointer to disk block of data pointers
 - 4KB block size => 1K data blocks => 4MB
- Doubly indirect block pointer
 - Doubly indirect block => 1K indirect blocks
 - 4GB (+ 4MB + 48KB)

FFS inode

- Metadata
 - File owner, access permissions, access times, ...
- Set of 12 data pointers
 - With 4KB blocks => max size of 48KB
- Indirect block pointer
 - pointer to disk block of data pointers
 - 4KB block size => 1K data blocks => 4MB
- Doubly indirect block pointer
 - Doubly indirect block => 1K indirect blocks
 - 4GB (+ 4MB + 48KB)
- Triply indirect block pointer
 - Triply indirect block => 1K doubly indirect blocks
 - 4TB (+ 4GB + 4MB + 48KB)

Inode Array

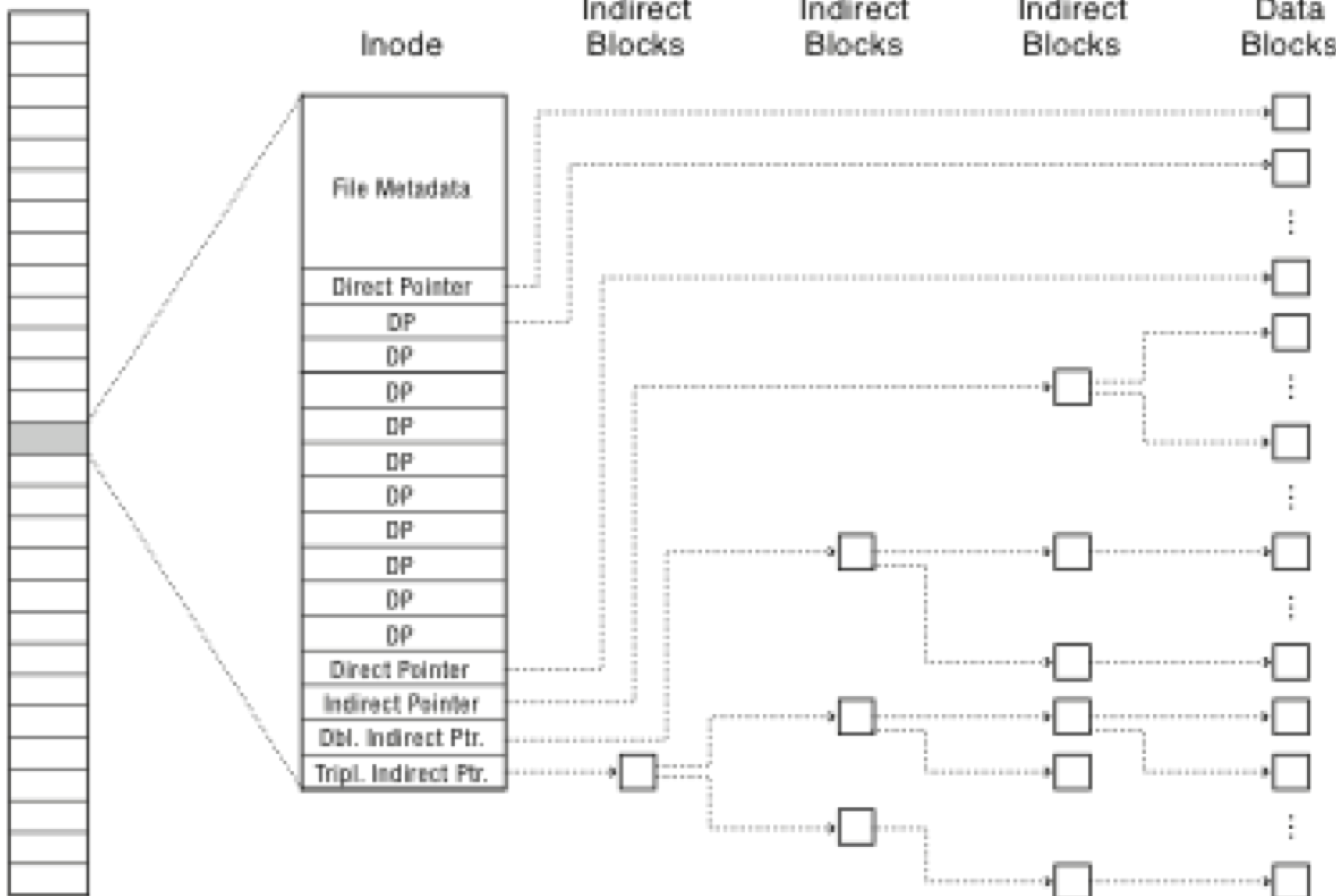

FFS Asymmetric Tree

- Small files: shallow tree
 - Efficient storage for small files
- Large files: deep tree
 - Efficient lookup for random access in large files
- Sparse files: only fill pointers if needed

FFS Locality

- Block group allocation
 - Block group is a set of nearby cylinders
 - Files in same directory located in same group
 - Subdirectories located in different block groups
- inode table spread throughout disk
 - inodes, bitmap near file blocks
- First fit allocation
 - Small files fragmented, large files contiguous

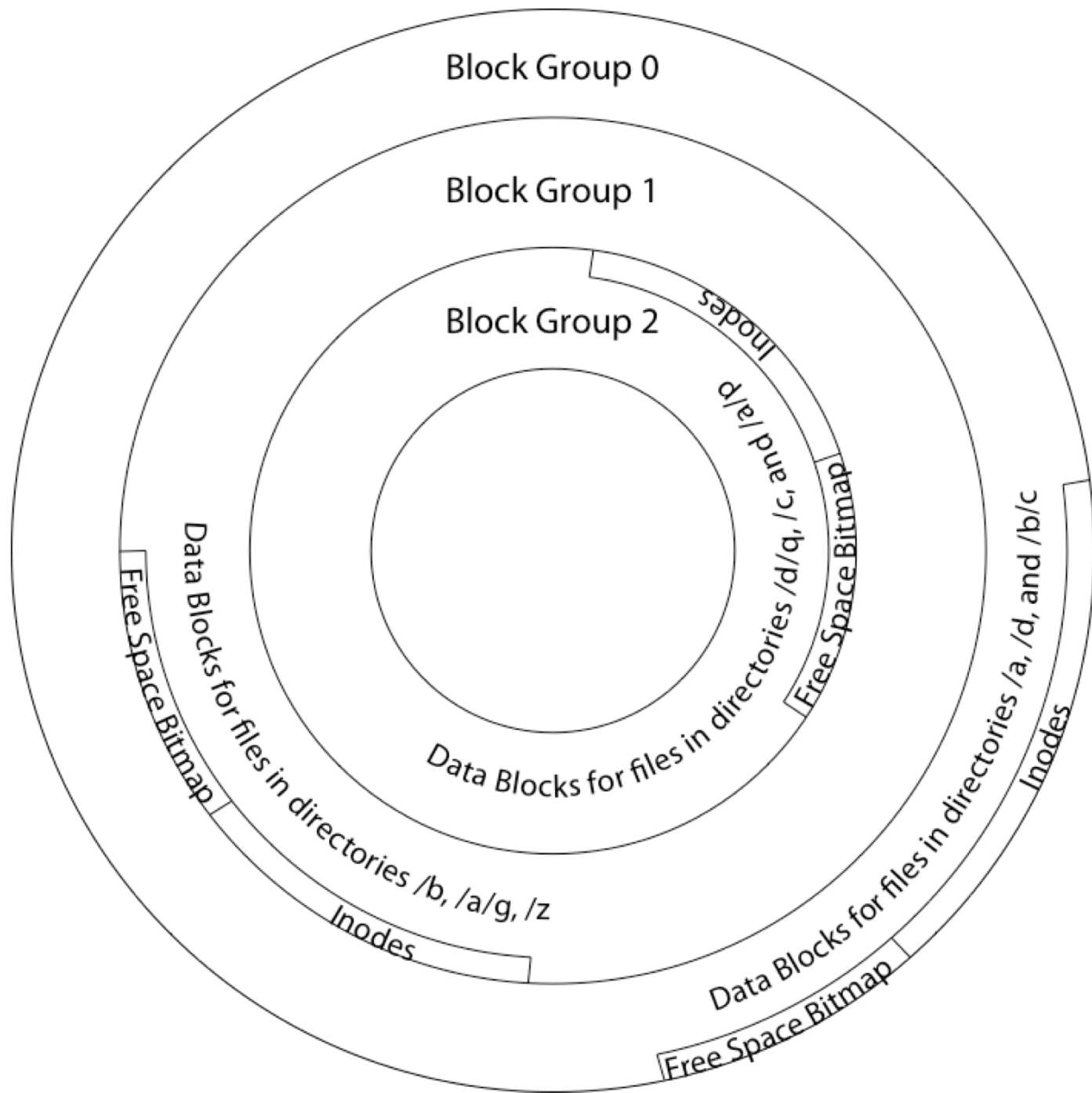

FFS First Fit Block Allocation

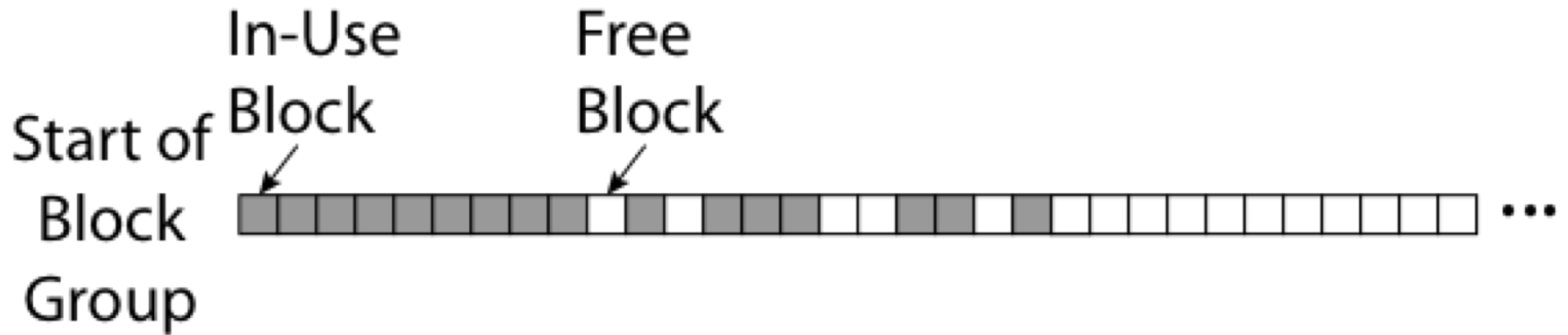

FFS First Fit Block Allocation

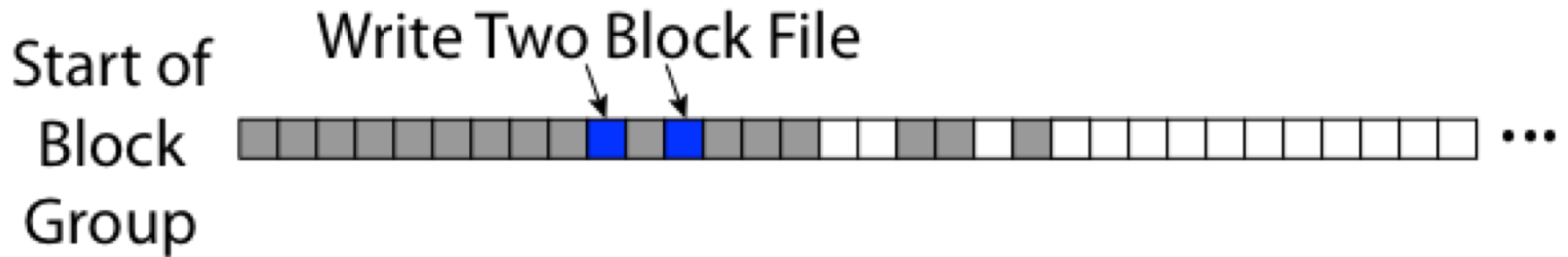

FFS First Fit Block Allocation

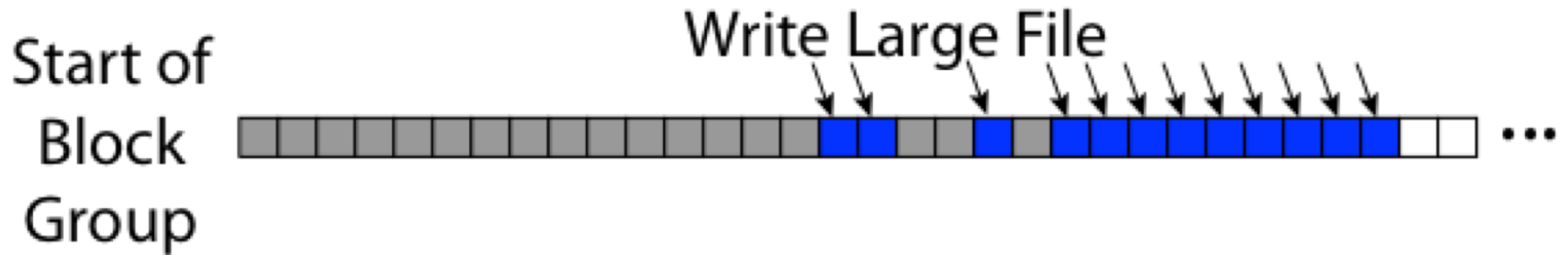

FFS

- Pros
 - Efficient storage for both small and large files
 - Locality for both small and large files
 - Locality for metadata and data
- Cons
 - Inefficient for tiny files (a 1 byte file requires both an inode and a data block)
 - Inefficient encoding when file is mostly contiguous on disk (no equivalent to superpages)
 - Need to reserve 10-20% of free space to prevent fragmentation

NTFS

- Master File Table
 - Flexible 1KB storage for metadata and data
- Extents
 - Block pointers cover runs of blocks
 - Similar approach in linux (ext4)
 - File create can provide hint as to size of file
- Journalling for reliability
 - Next chapter

NTFS Small File

Master File Table



MFT Record (small file)

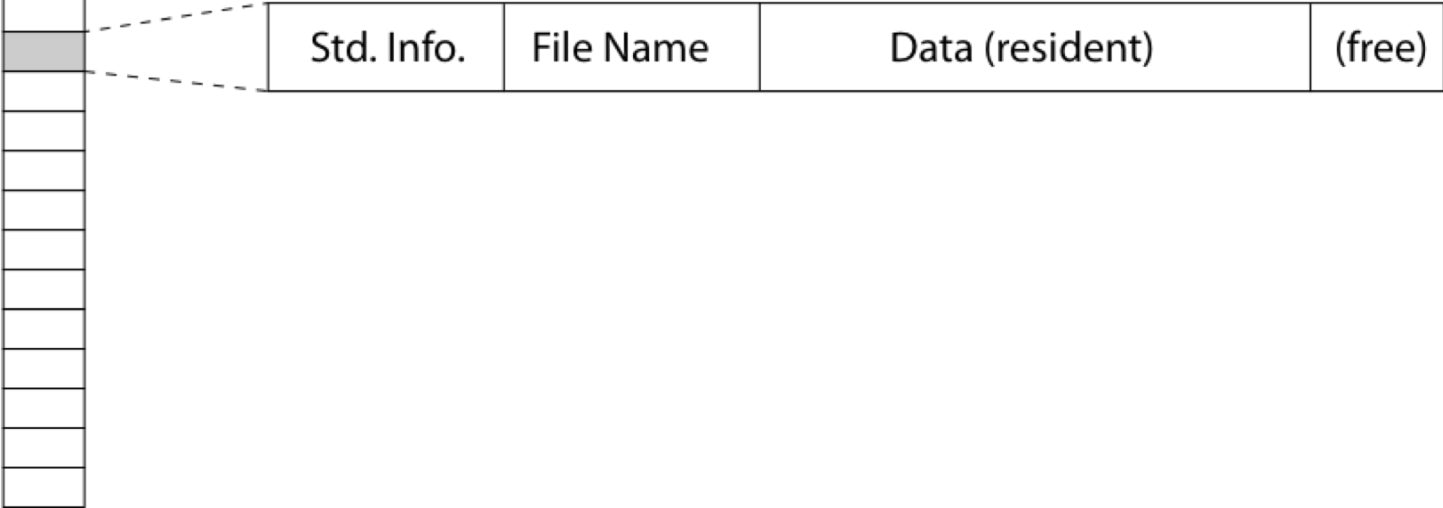

NTFS Medium-Sized File

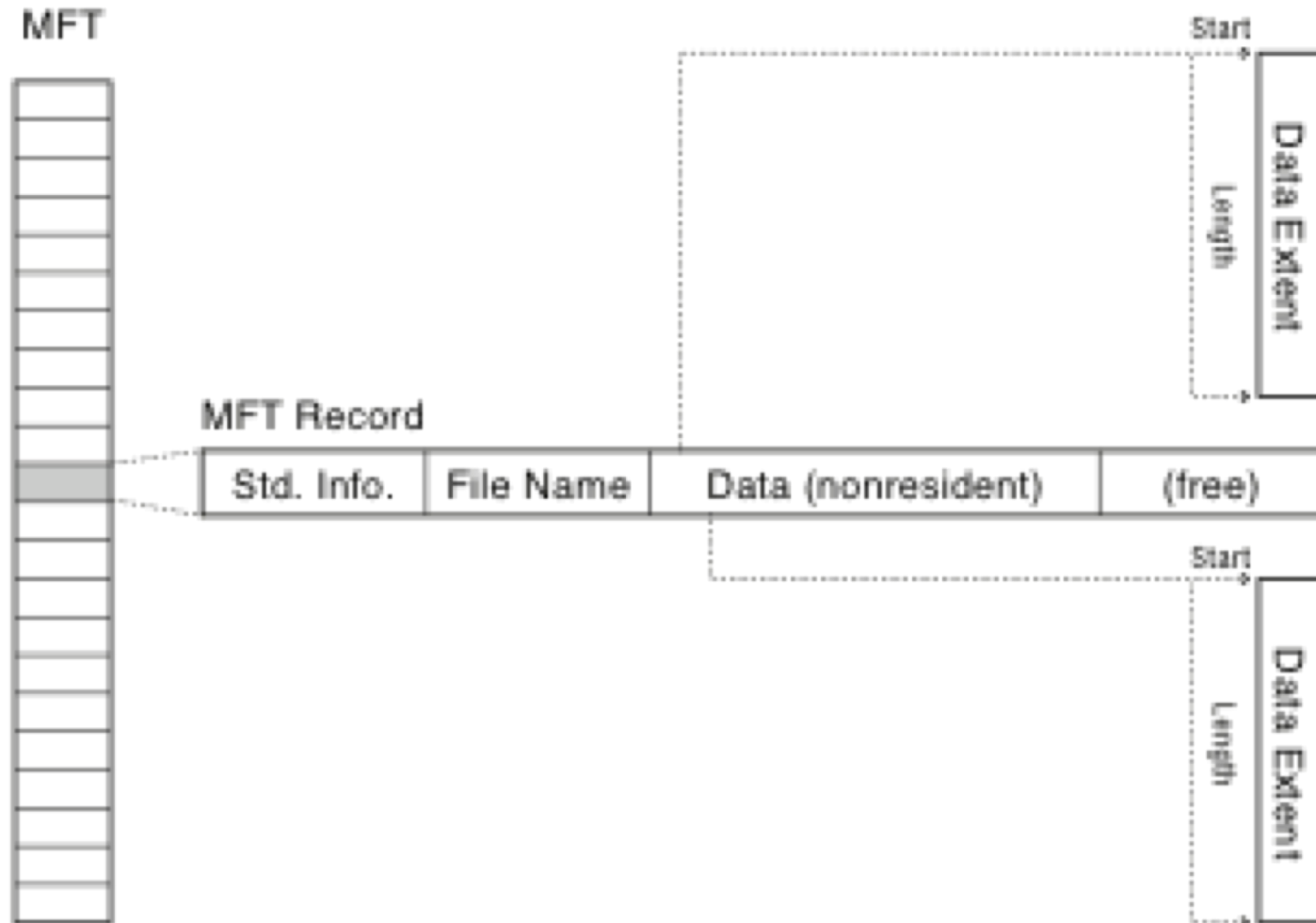

NTFS Indirect Block

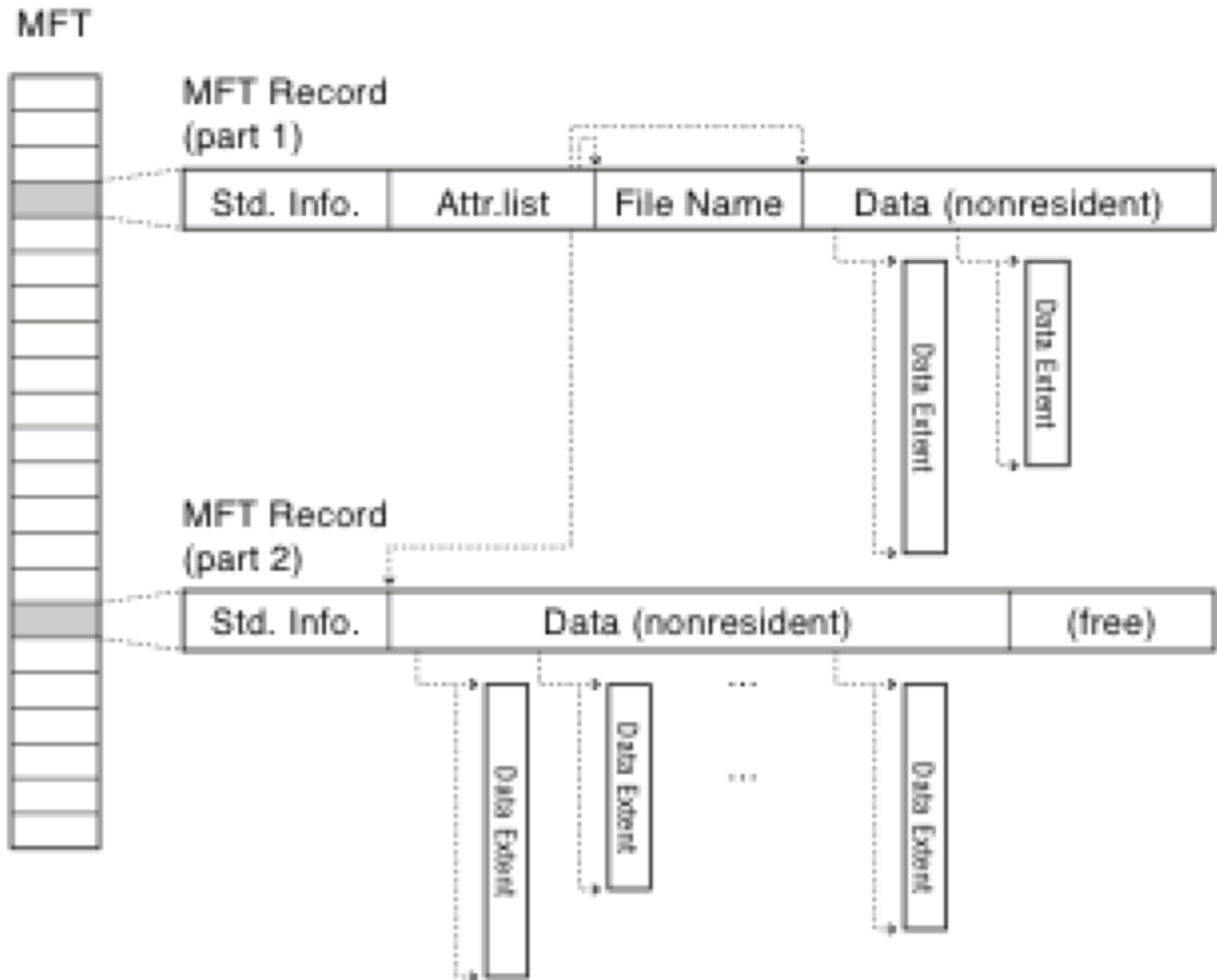

MFT

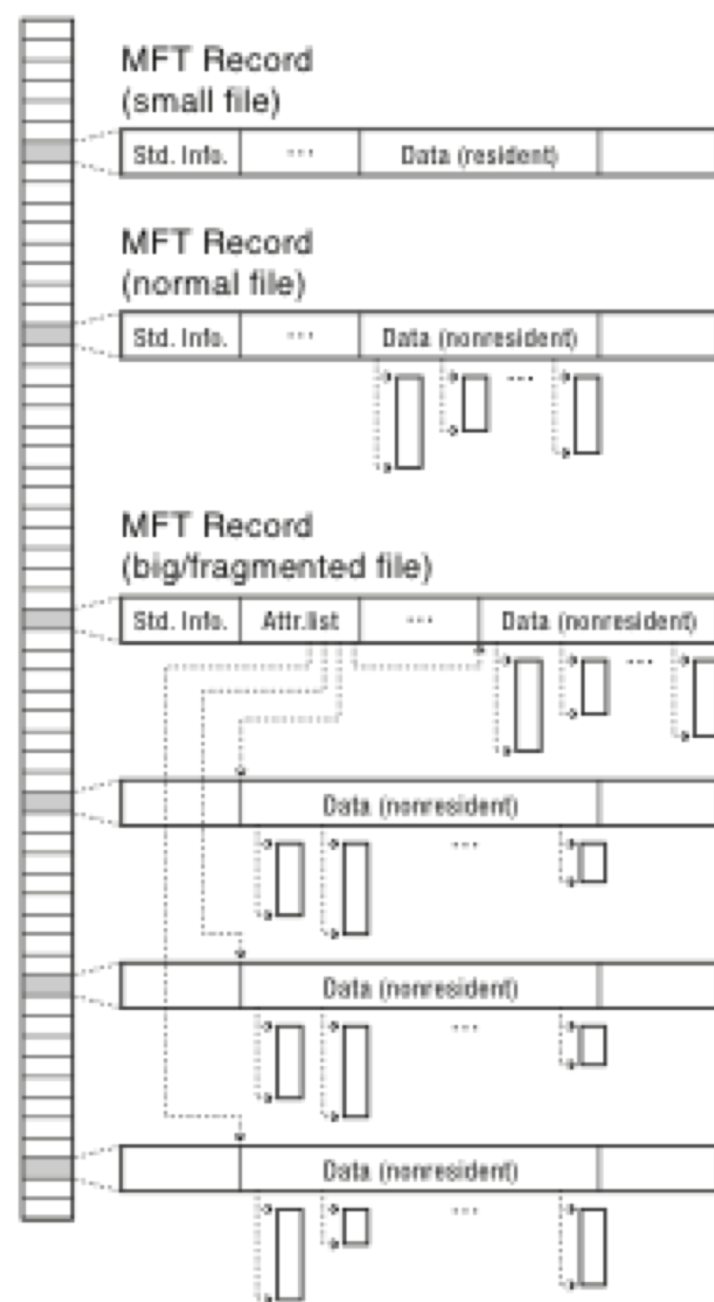

MFT

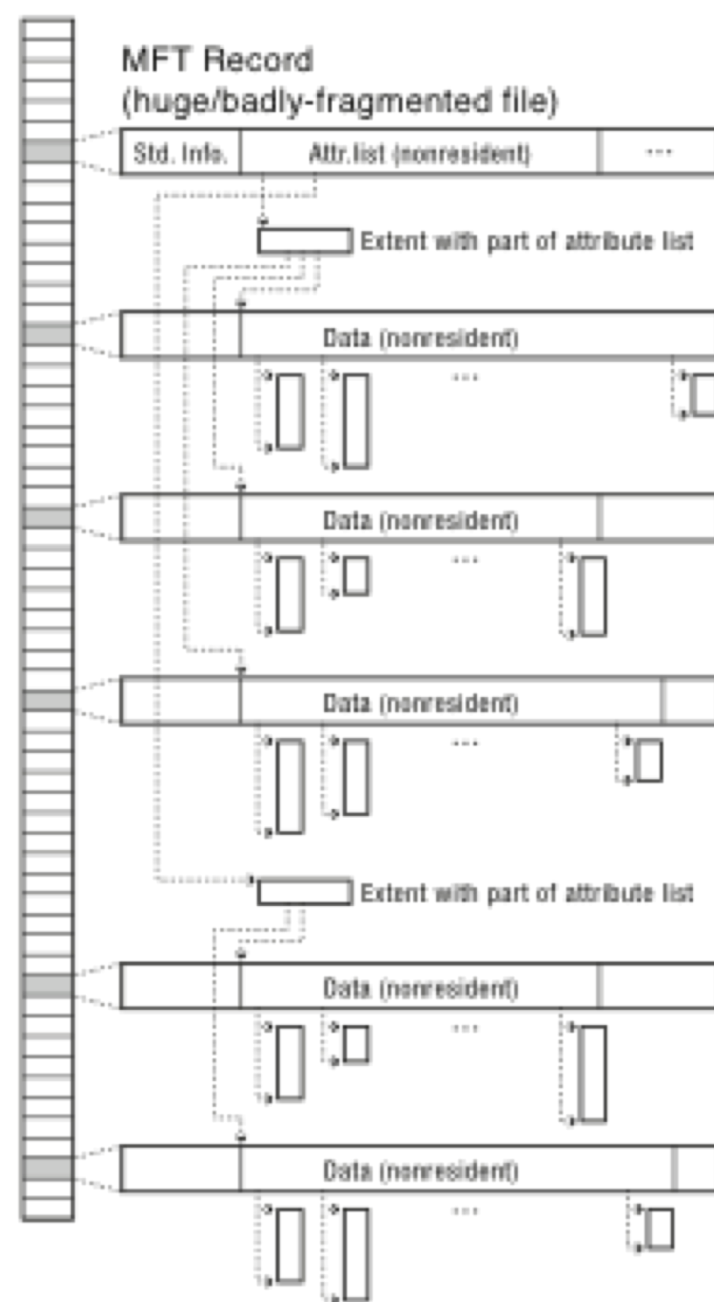

Named Data in a File System

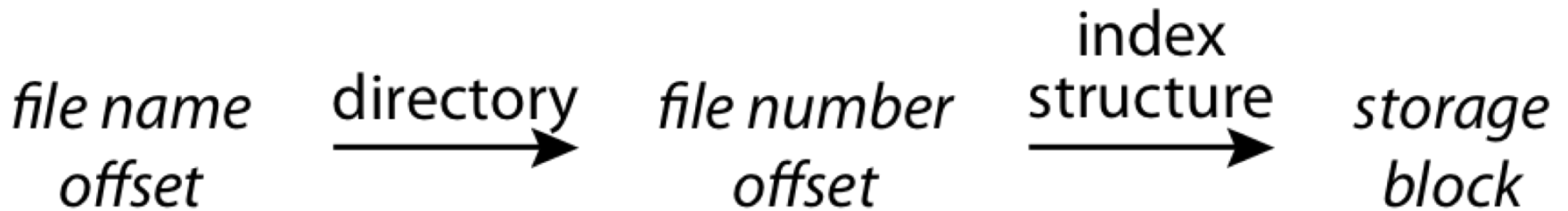

Directories Are Files

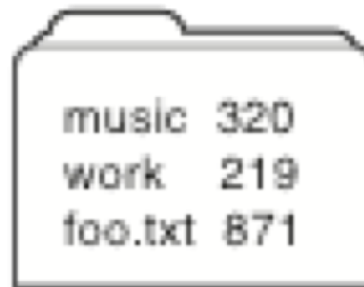

music	320
work	219
foo.txt	871

Recursive Filename Lookup

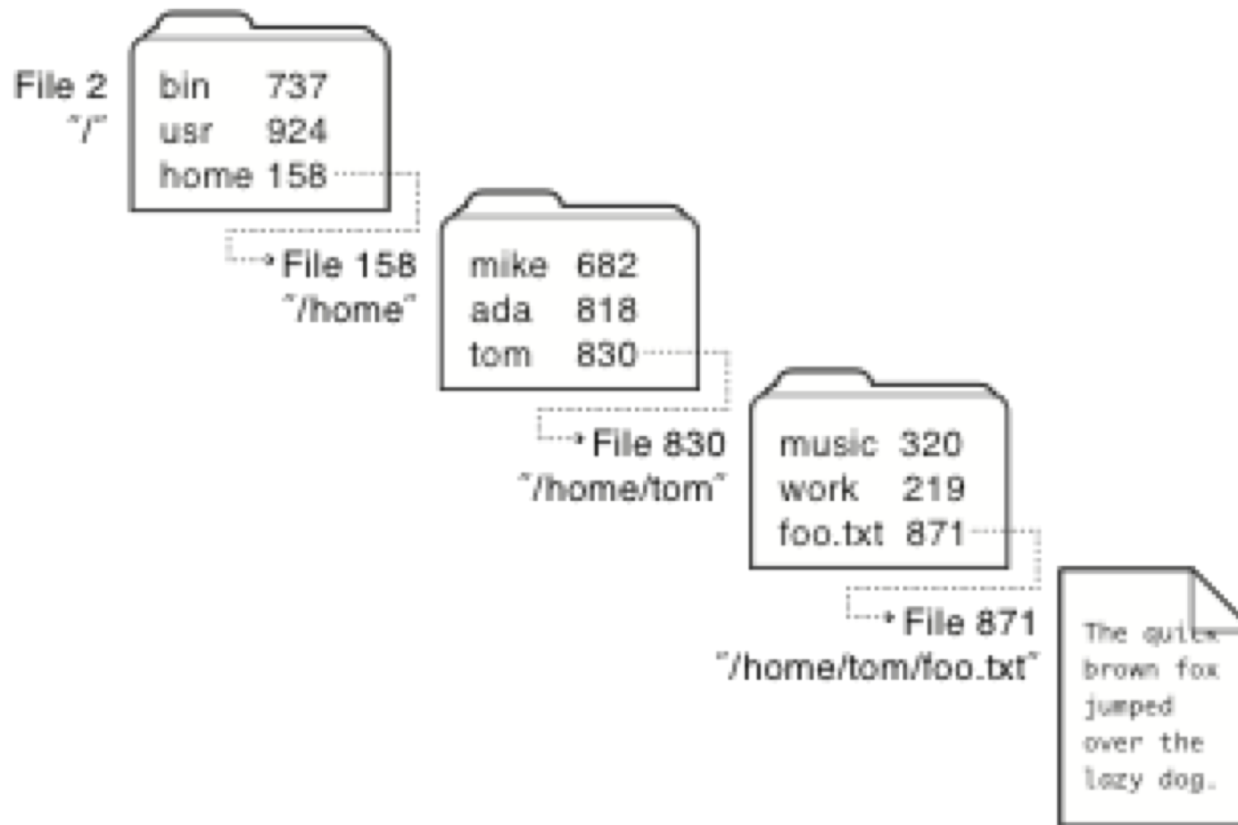

Directory Layout

Directory stored as a file

Linear search to find filename (small directories)



Large Directories: B Trees

Search for Hash (foo.txt) = 0x30

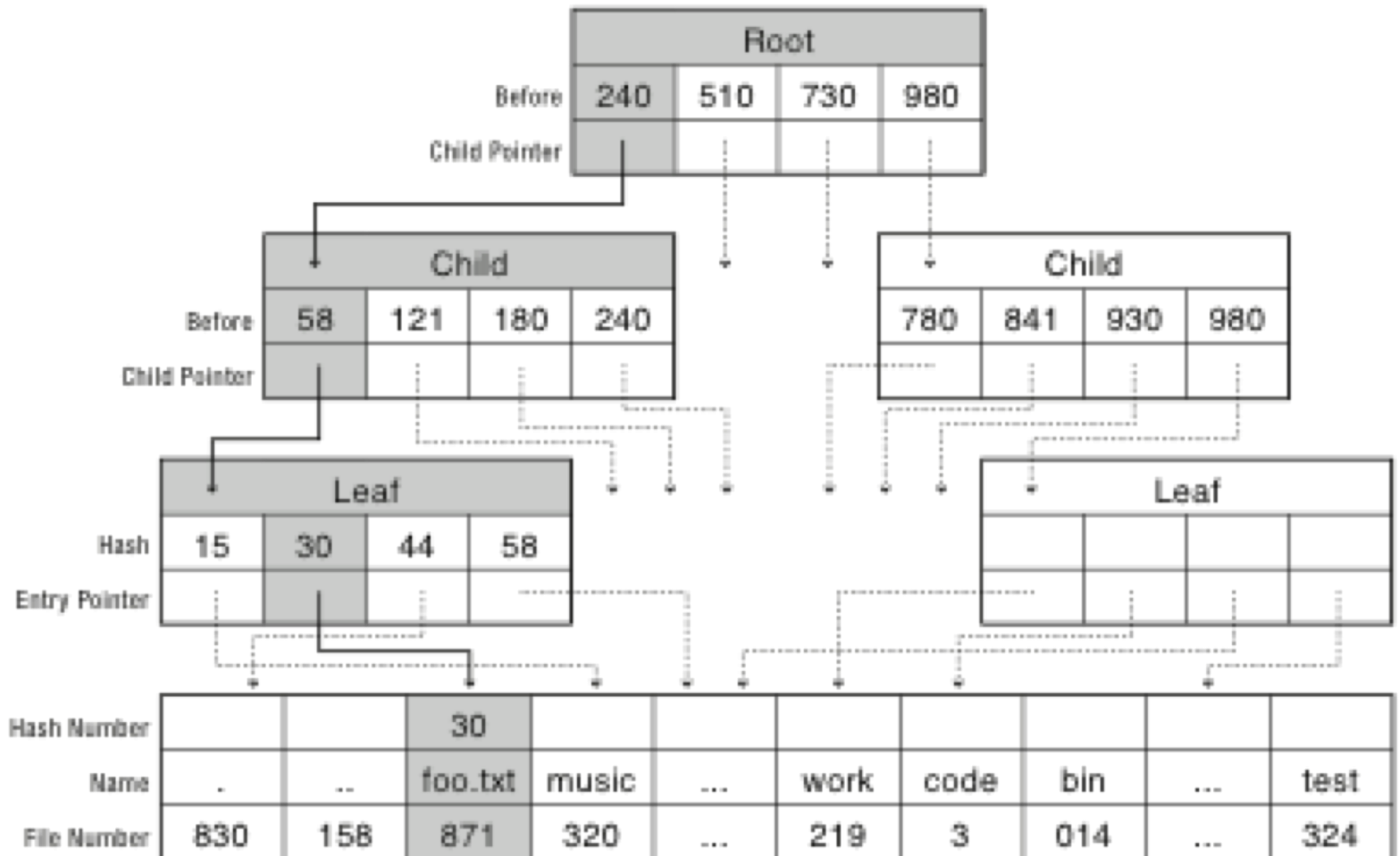

Large Directories: Layout

File Containing Directory

